

Surface Texture & Machining Symbols

Surface Conditions Vary

- **Machined**
- **Cast**
- **Forged**

What is needed for product function?

- **Smooth**
- **Rough**
- **Patterned**

Extra Stock for Castings

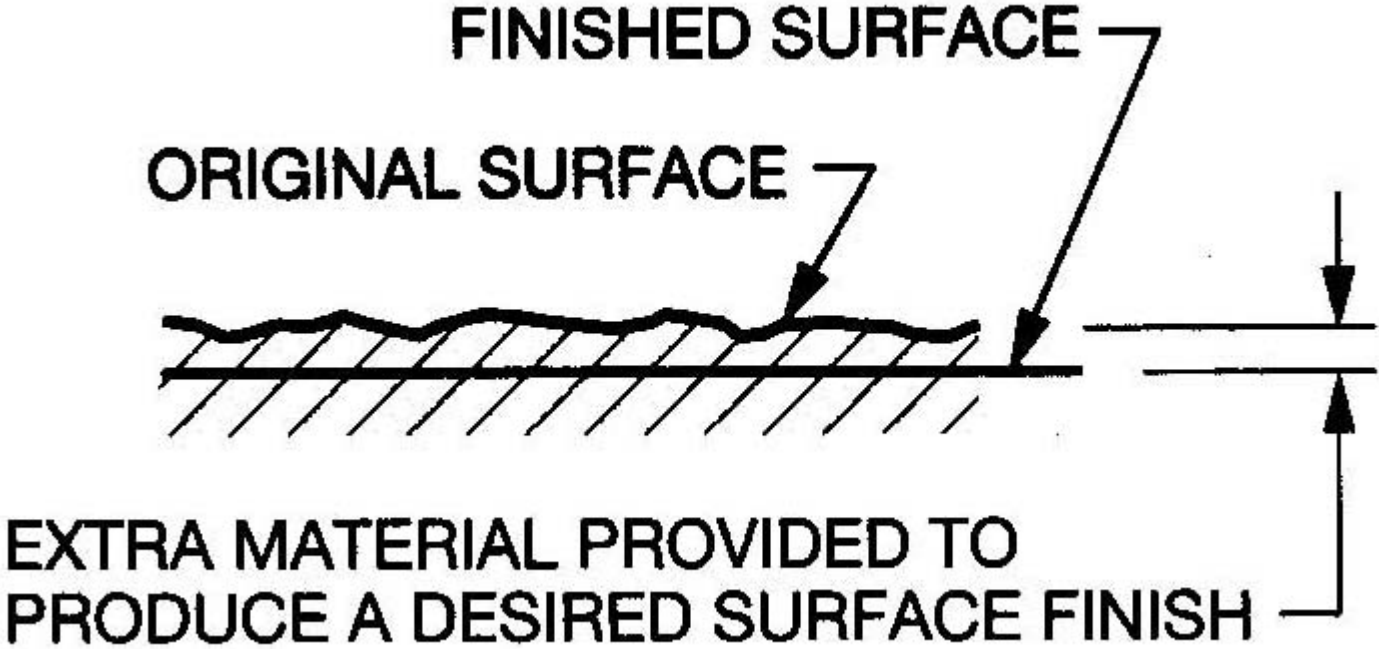

Machined Surfaces

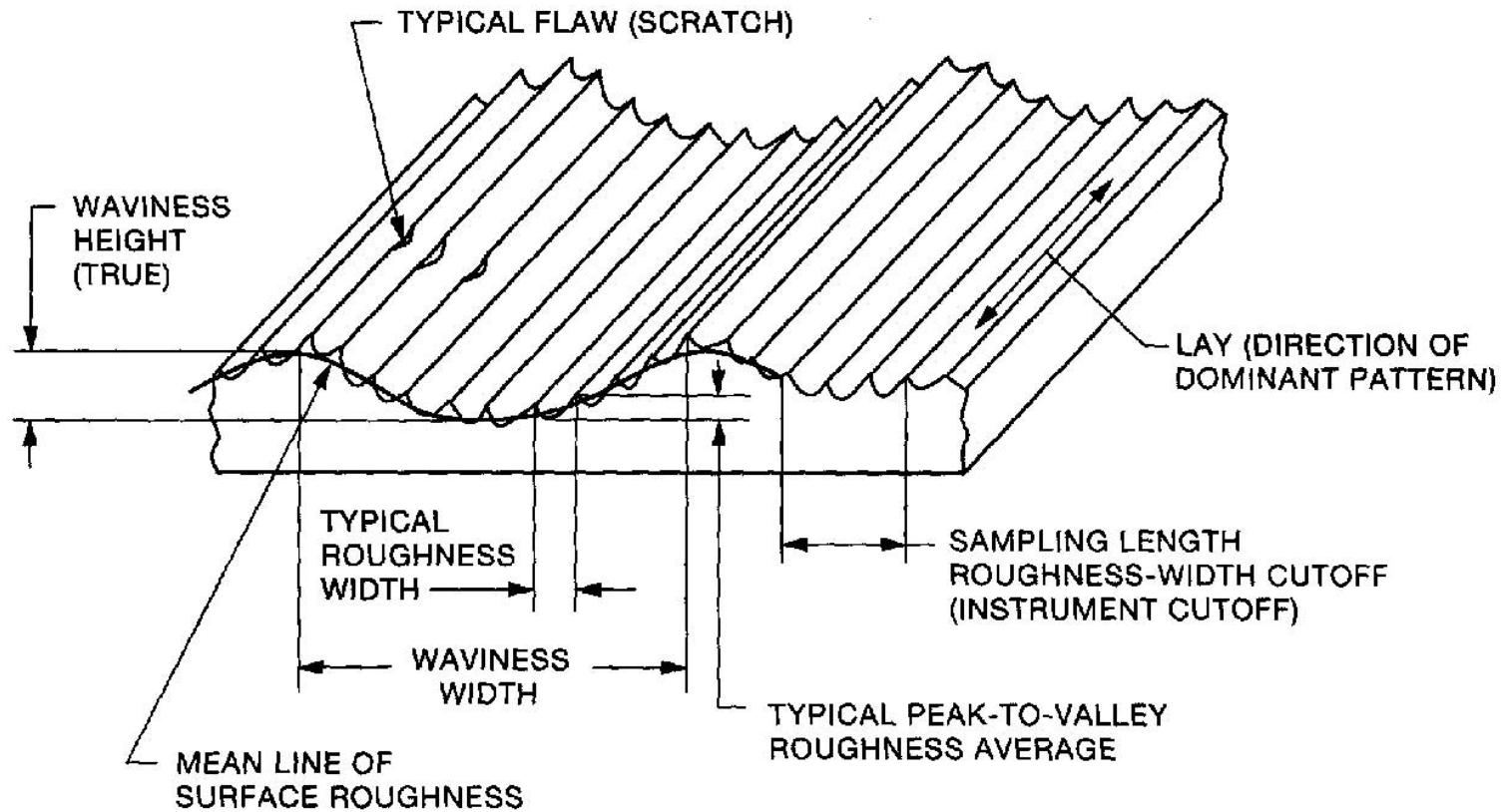

Surface Roughness by Process

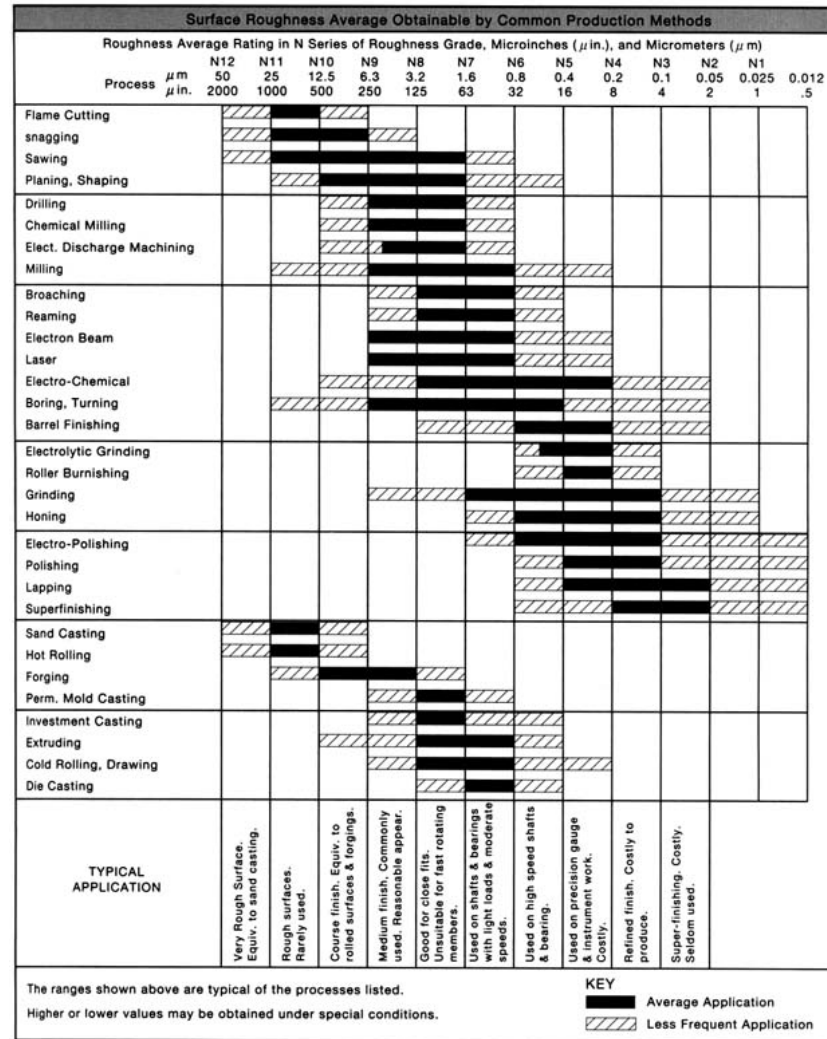
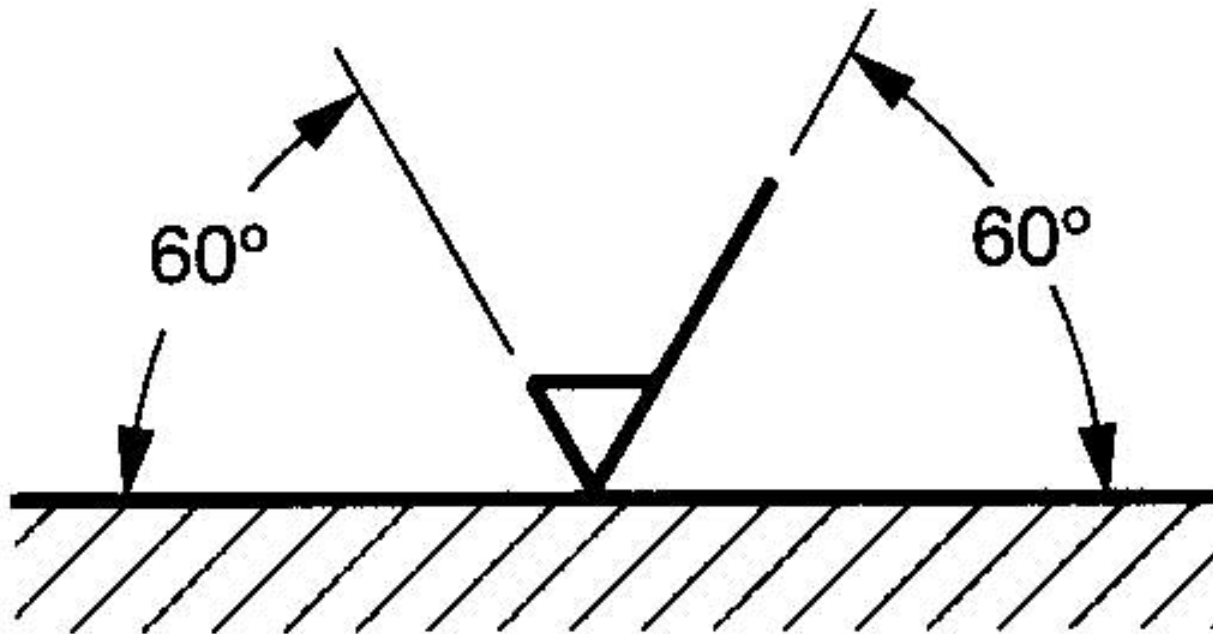

FIGURE 11-8 ■ Surface roughness range for common production methods

Machining Symbols



Finish Marks

- Shown in edge view

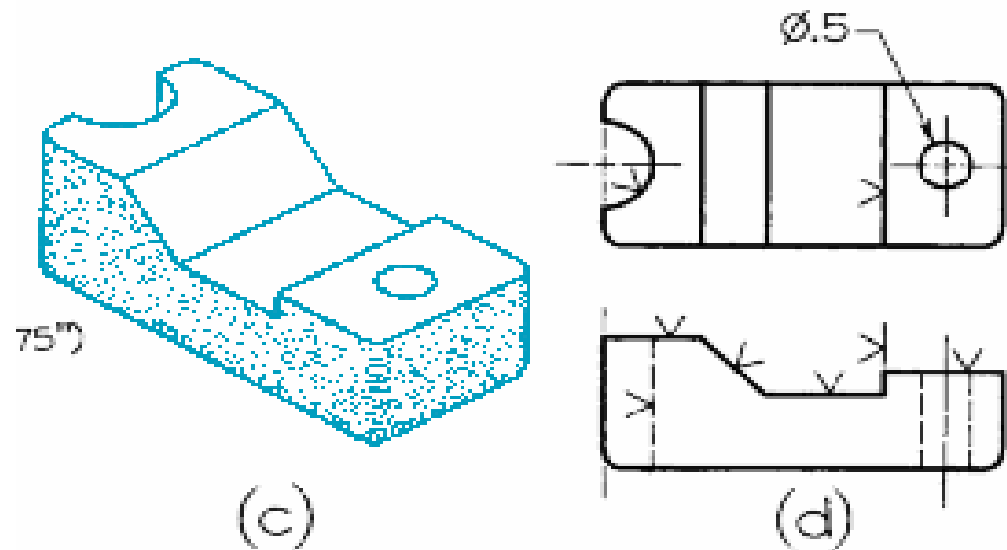
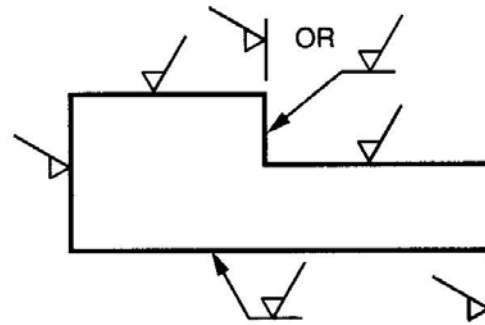
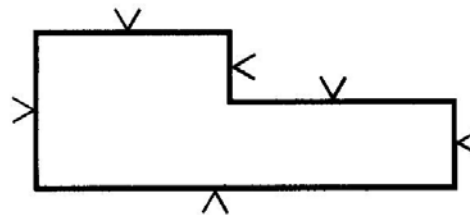

FIGURE 12.20 Finish Marks.

Recommended Symbol



(A) RECOMMENDED SYMBOL



(B) FORMER MACHINING SYMBOLS

Casting Example

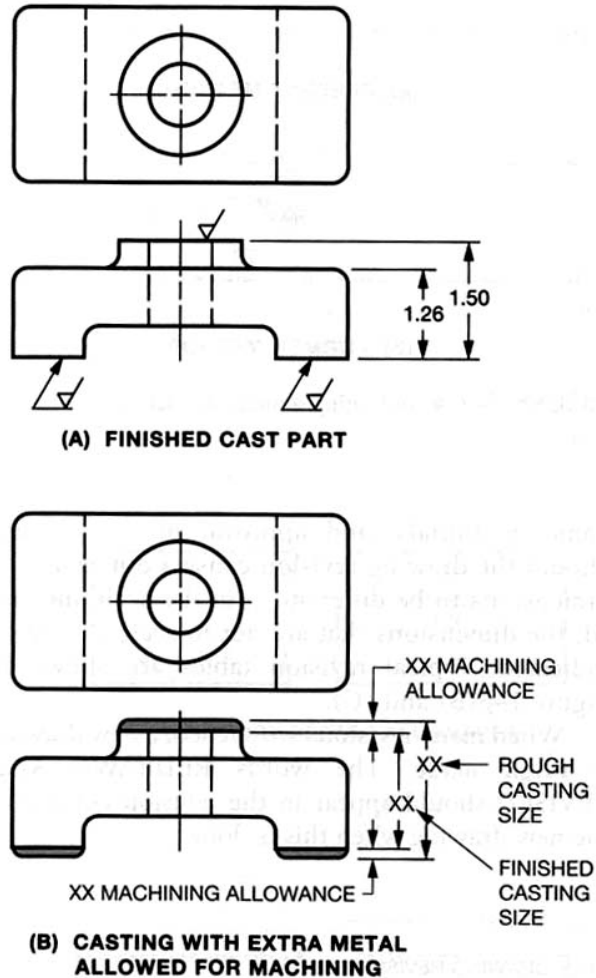

FIGURE 7-3 ■ Allowances for machining

Symbols

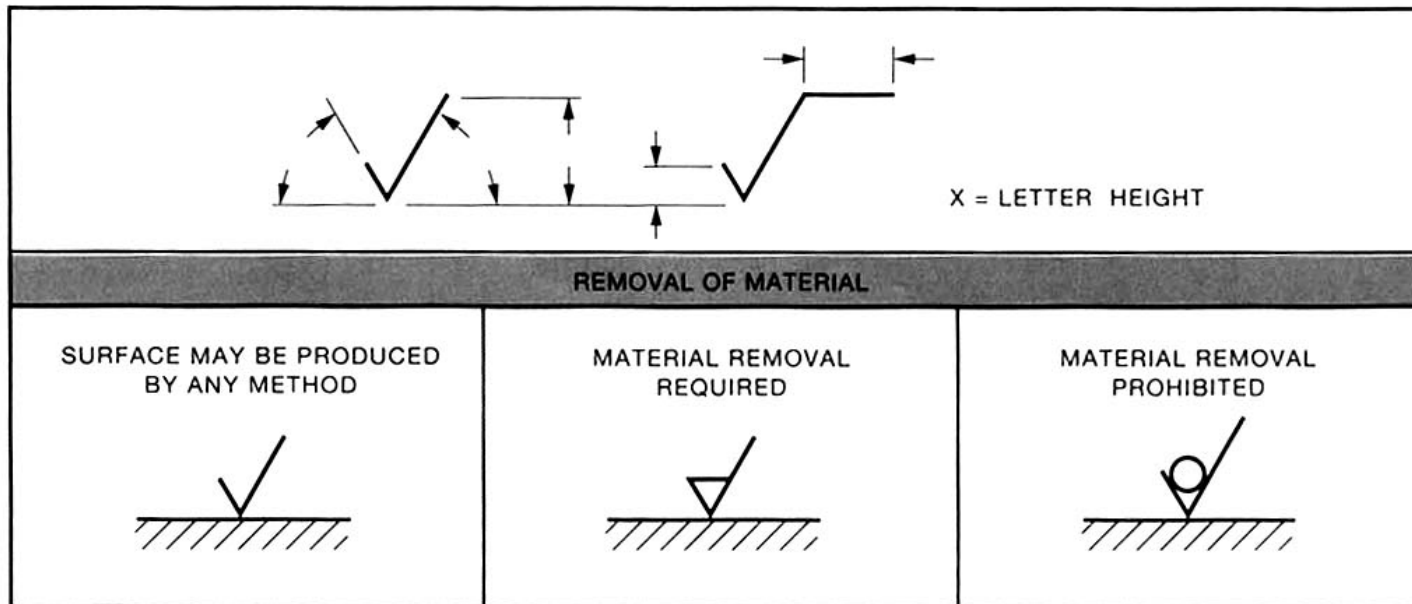

FIGURE 11-3 ■ Basic surface texture symbol

Complete Symbol

		<p>EXAMPLE</p>
<p>BASIC SURFACE TEXTURE SYMBOL</p> <p>✓</p>	<p>MAXIMUM WAVINESS SPACING RATING (C). SPECIFY IN INCHES OR MILLIMETERS. HORIZONTAL BAR ADDED TO BASIC SYMBOL.</p> <p>✓ </p>	
<p>ROUGHNESS AVERAGE VALUES (A). SPECIFY IN MICROINCHES, MICROMETERS, OR ROUGHNESS GRADE NUMBERS.</p> <p>63/ N7/</p>	<p>LAY SYMBOL (E)</p> <p>✓ </p>	
<p>MAXIMUM AND MINIMUM ROUGHNESS AVERAGE VALUES (A), SPECIFY IN MICROINCHES, MICROMETERS, OR ROUGHNESS GRADE NUMBERS.</p> <p>63/32/ N7/ N6/</p>	<p>ROUGHNESS SAMPLING LENGTH OR CUTOFF RATING (D). WHEN NO VALUE IS SHOWN USE .03 INCH (0.8 MILLIMETERS).</p> <p>✓ </p>	
<p>MAXIMUM WAVINESS HEIGHT RATING (B) SPECIFY IN INCHES OR MILLIMETERS. HORIZONTAL BAR ADDED TO BASIC SYMBOL.</p> <p>✓ </p>	<p>MACHINING ALLOWANCE (F). SPECIFY IN INCHES OR MILLIMETERS.</p> <p>✓ </p>	

NOTE: WAVINESS IS NOT USED IN ISO STANDARDS.

FIGURE 11-4 ■ Location of ratings and symbols on surface texture symbol

Example of Symbols

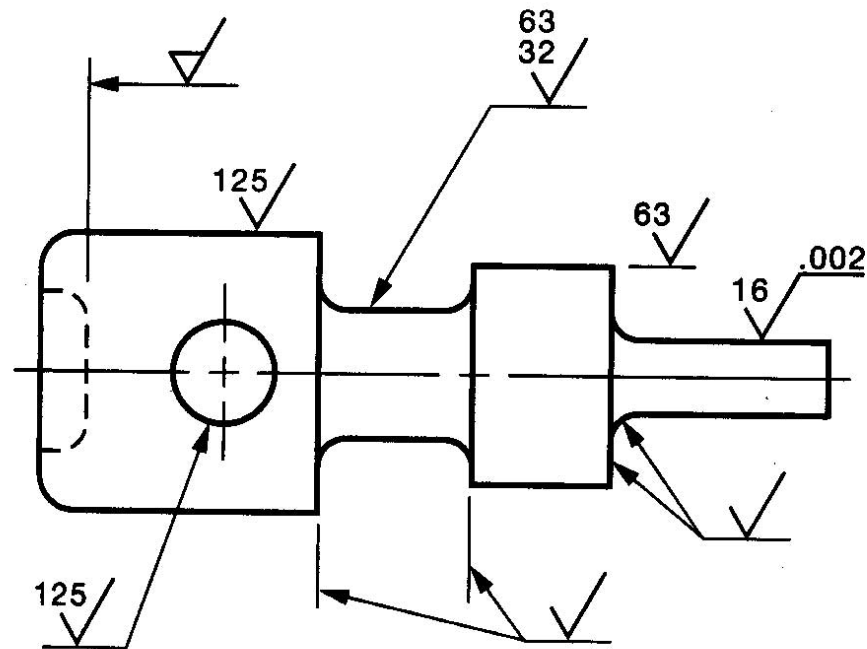

ALL SURFACES $250 \sqrt{\quad}$ UNLESS OTHERWISE SPECIFIED.

NOTE: VALUES SHOWN ARE IN MICROINCHES.

Indicating Machining Allowance

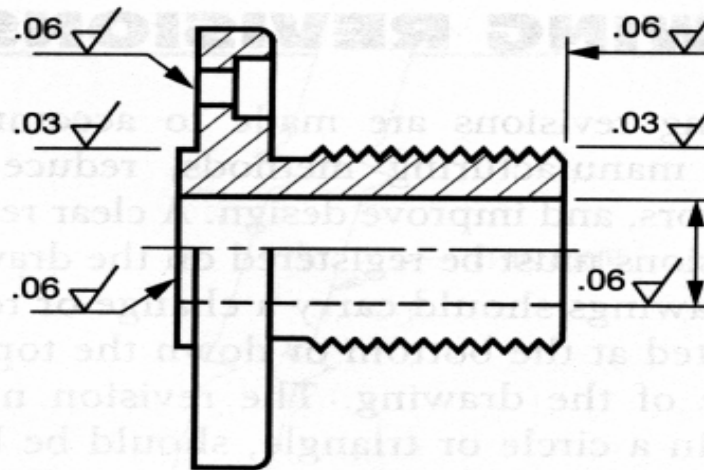

FIGURE 7-5 ■ The value of the machining allowance as shown on the drawing

Machining Notes

- **Finish All Over (FAO)**

Application

MICROMETERS RATING	MICROINCHES RATING	APPLICATION
25 ✓	1000 ✓	Rough, low grade surface resulting from sand casting, torch or saw cutting, chipping, or rough forging. Machine operations are not required because appearance is not objectionable. This surface, rarely specified, is suitable for unmachined clearance areas on rough construction items.
12.5 ✓	500 ✓	Rough, low grade surface resulting from heavy cuts and coarse feeds in milling, turning, shaping, boring, and rough filing, disc grinding and snagging. It is suitable for clearance areas on machinery, jigs, and fixtures. Sand casting or rough forging produces this surface.
6.3 ✓	250 ✓	Coarse production surface, for unimportant clearance and cleanup operation, resulting from coarse surface grind, rough file, disc grind, rapid feeds in turning, milling, shaping, drilling, boring, grinding, etc., where tool marks are not objectionable. The natural surfaces of forgings, permanent mold castings, extrusions, and rolled surfaces also produce this roughness. It can be produced economically and is used on parts where stress requirements, appearance, and conditions of operations and design permit.
3.2 ✓	125 ✓	The roughest surface recommended for parts subject to loads, vibration, and high stress. It is also permitted for bearing surfaces when motion is slow and loads light or infrequent. It is a medium commercial machine finish produced by relatively high speeds and fine feeds taking light cuts with sharp tools. It may be economically produced on lathes, milling machines, shapers, grinders, etc., or on permanent mold castings, die castings, extrusion, and rolled surfaces.
1.6 ✓	63 ✓	A good machine finish produced under controlled conditions using relatively high speeds and fine feeds to take light cuts with sharp cuttings. It may be specified for close fits and used for all stressed parts, except fast rotating shafts, axles, and parts subject to severe vibration or extreme tension. It is satisfactory for bearing surfaces when motion is slow and loads light or infrequent. It may also be obtained on extrusions, rolled surfaces, die castings and permanent mold casting when rigidly controlled.
0.8 ✓	32 ✓	A high-grade machine finish requiring close control when produced by lathes, shapers, milling machines, etc., but relatively easy to produced by centerless, cylindrical, or surface grinders. Also, extruding, rolling or die casting may produce a comparable surface when rigidly controlled. This surface may be specified in parts where stress concentration is present. It is used for bearings when motion is not continuous and loads are light. When finer finishes are specified, production costs rise rapidly; therefore, such finishes must be analyzed carefully.
0.4 ✓	16 ✓	A high quality surface produced by fine cylindrical grinding, emery buffing, coarse honing, or lapping, it is specified where smoothness is of primary importance, such as rapidly rotating shaft bearings, heavily loaded bearing and extreme tension members.
0.2 ✓	8 ✓	A fine surface produced by honing, lapping, or buffing. It is specified where packings and rings must slide across the direction of the surface grain, maintaining or withstanding pressures, or for interior honed surface of hydraulic cylinders. It may also be required in precision gauges and instrument work, or sensitive value surfaces, or on rapidly rotating shafts and on bearings where lubrication is not dependable.
0.1 ✓	4 ✓	A costly refined surface produced by honing, lapping and buffing. It is specified only when he design requirements make it mandatory. It is required in instrument work, gauge work, and where packing and rings must slide across the direction of surface grain such as on chrome plated piston rods, etc. where lubrication is not dependable.
0.05 ✓ 0.025 ✓	2 ✓ 1 ✓	Costly refined surfaces produced by only the finest of modern honing, lapping, buffing, and superfinishing equipment. These surfaces may have a satin or highly polished appearance depending on the finishing operation and material. These surfaces are specified only when design requirements make it mandatory. They are specified on fine or sensitive instrument parts or other laboratory items, and certain gauge surfaces, such as precision gauge blocks.

FIGURE 11-9 ■ Surface roughness description and application

Surface Roughness

